

# LT1472M

## 1 6X 16 Dot Matrix LED Unit for Outdoor Use

### ■ Features

1. 16×16 dot matrix LED unit
2. Active display size: 31.9mm square
3. Three color emission by use of dichromatic LED
4. Radiation color: Red, yellow-green and orange (mixed color)
5. Wide viewing angle
6. Built-in shift registers, latch circuits, LED driver ICS, scanning line select circuits and luminance adjusting circuits
7. Clock frequency: 3MHz
8. Dynamic drive (Duty ratio: 1/4)

### ■ Outline Dimensions (Unit: mm)

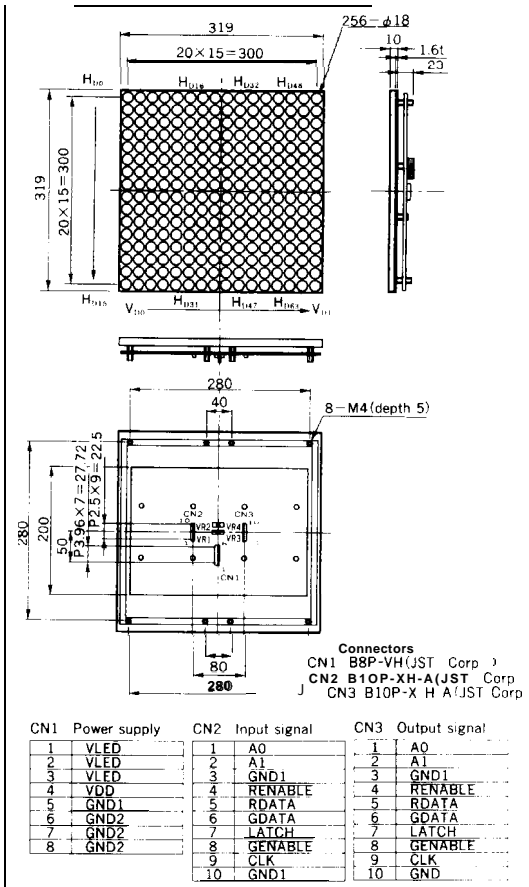

### ■ Block Diagram

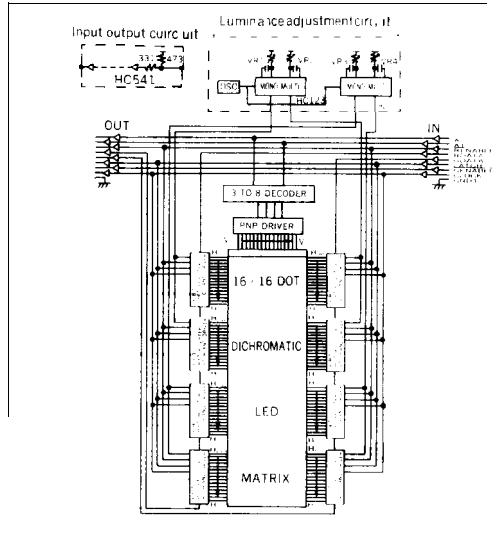

### ■ Terminal Functions

Connector	Pin No.	Name	Function
CN1 (Power supply)	1 to 3	V <sub>LED</sub>	Power supply for LED
	4	V <sub>DD</sub>	Power supply for IC
	5	GND1	Ground for IC
	6 to 8	GND2	Ground for LED
CN2 (Input signal)	1, 2	A <sub>0</sub> , A <sub>1</sub>	Address specification signal for column driver
	3	GND1	Ground for IC
	4	RENABLE	"L": Each dot can be driven in accordance with red data
	5	RDATA	Serial data input for red (H: lit, L: no lit)
	6	GDATA	Serial data input for Yellow-green (H: lit, L: no lit)
	7	LATCH	"L": "H": The contents are latched
	8	GENABLE	"L": Each dot can be driven in accordance with data
	9	CLOCK	Clock signal for data transmission in the shift-register. (L: "H": The data are shifted)
	10	GND1	Ground for IC
	CN3 (Output signal)	1, 2	A <sub>0</sub> , A <sub>1</sub>
3		GND1	Ground for IC
4		RENABLE	Buffered the input signal RENABLE
5		RDATA	Input signal is generated through 64-bit shift register in the unit.
6		GDATA	Buffered the input signal
7		LATCH	LATCH
8		GENABLE	Buffered the input signal GENABLE
9		CLOCK	Buffered the input signal CLOCK
10		GND1	Ground for IC

### ■ Absolute Maximum Ratings

(Ta = 25°C)

Parameter	Symbol	Rating	Unit
IC supply voltage	V <sub>DD</sub>	-0.3 to +5.5	V
LED supply voltage	V <sub>LED</sub>	-0.3 to +13	V
Input voltage	V <sub>I</sub>	*1 -0.3 to V <sub>DD</sub> +0.3	V
LED current dissipation	I <sub>LED</sub>	*2, 8.0	A
Operating temperature range	Topr 1	*3 -10 to +45	°C
	Topr 2	*4 -10 to +65	°C
	Topr 3	*5 -10 to +75	°C
Storage temperature range	Tstg	-20 to +100	°C

\*1 V<sub>I</sub> < V<sub>DD</sub> at V<sub>DD</sub> ≤ 5.5

%2, \*3 When all dots are lit, Duty ratio: 1/4

\*4 When half rate of lighting

\*5 When quarter rate of lighting

### ■ Electro-optical Characteristics

(Ta = 25°C, V<sub>CC</sub> = 5V, V<sub>LED</sub> = 5V)

Parameter	Symbol	MIN	TYP	MAX	Unit
Operating IC supply voltage	V <sub>DD</sub>	4.75	5.0	5.25	v
Operating LED supply voltage	v <sub>LED</sub>	11.5	12.0	12.5	V
IC current dissipation	I <sub>DD</sub>		0.35		mA
LED current dissipation	I <sub>LED</sub>		*6, 7.0		A
Input voltage	V <sub>II</sub>			1.5	V
	V <sub>IH</sub>	3.5			v
Input current	I <sub>IL</sub>			0.12	mA
	I <sub>IH</sub>			0.1	μA
Clock frequency	f <sub>CLK</sub>			3.0	MHz
Frame frequency	f <sub>FR</sub>	125	200		Hz
Luminance	Red		1300		cd/m <sup>2</sup>
	Yellow-green		900		
Peak emission wavelength	Red		660		nm
	Yellow-green		565		
Spectrum radiation bandwidth	Red		20		nm
	Yellow-green		30		

\*6, \*7 Duty ratio: 1/4, When all dots are lit, f<sub>FR</sub> = 200Hz

6

### Interface Signals

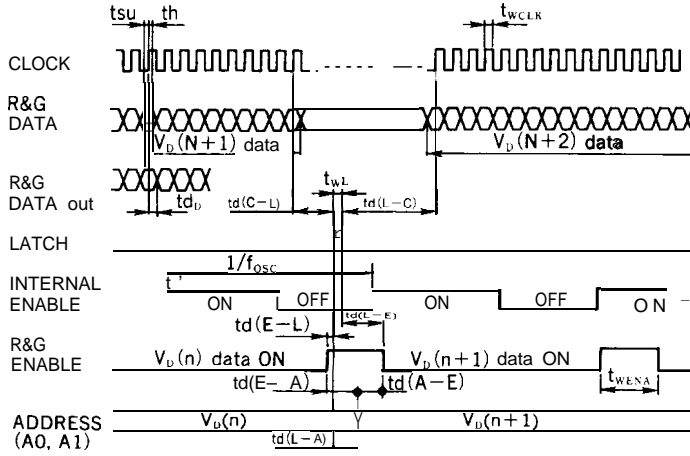

### Connections Method

